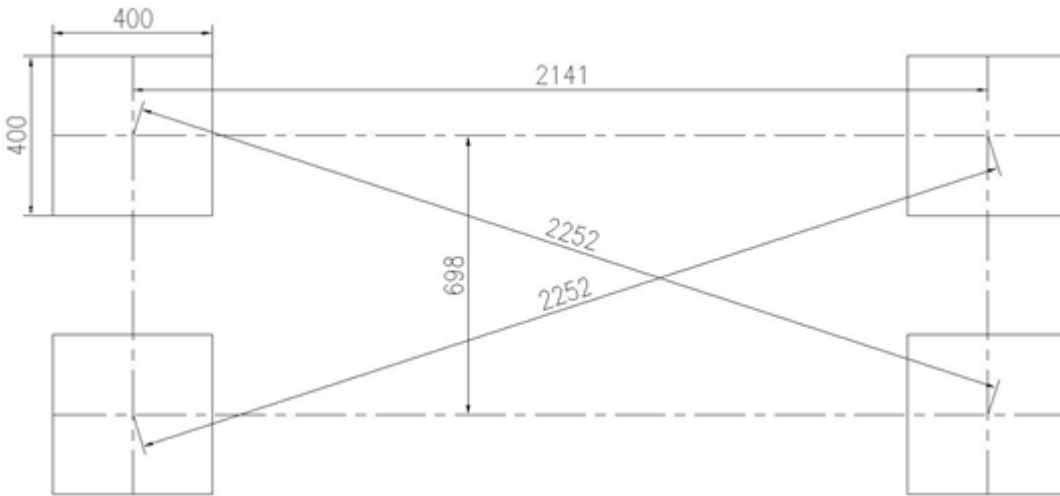

TABLE TENNIS TABLE INSTALLATION

Ground Construction Instructions (J-Bolts)

Excavate a hole as per the drawing, measuring 400*400*350mm.



Pour concrete into the hole to form the basic layer of 100mm. And combine the J-bolt with installation mould and put the bolts into the hole. (Refer to the diagram for space and size). Pour concrete of 1:2:3.5 into the hole (concrete mark shall not less than 325#), smooth the surface.

Make sure the bolts are perpendicular and 20-30mm above the ground surface. Disassembling the mould after the concrete is slightly harden, retouch the concrete surface to remain level with the original ground surface. Guard the site for 24 hours to keep it from being used or touched.

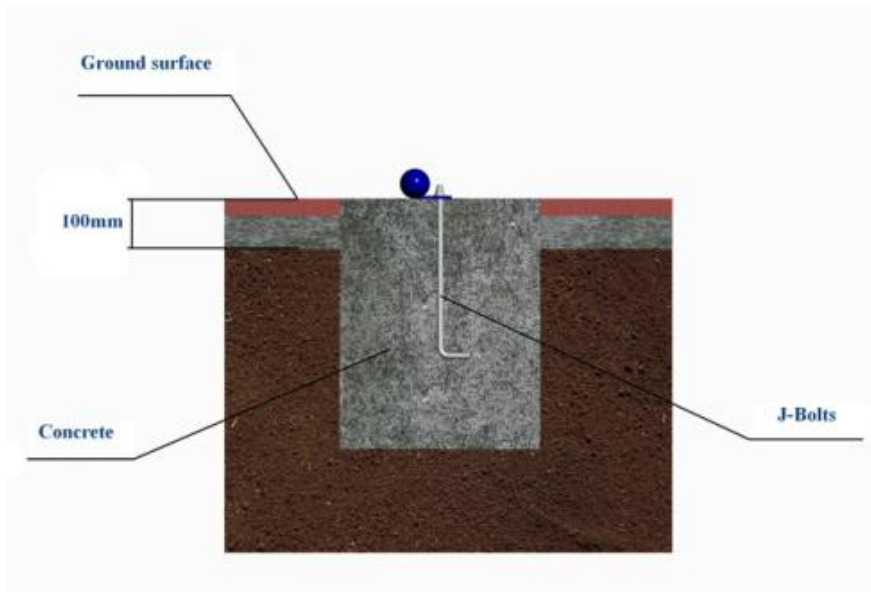

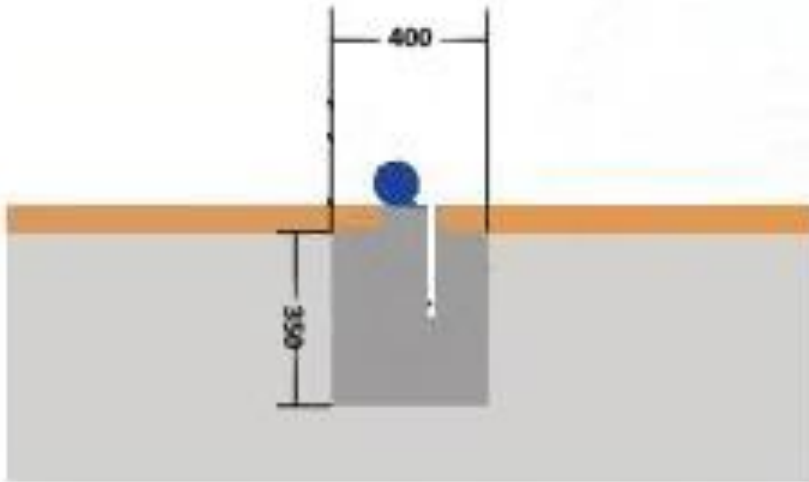

After the concrete is totally hardened, fasten the equipment onto the installed J-bolt with 4*M12 flat washer, spring washer and nut (see pics below). After installation, check the perpendicularity of the equipment to ground surface with tolerance less than 1/100.

Installation finished.



The Base is attached to the underneath of the table as shown. The cross-struts used to provide stability. Note various moulds have been used, in each design the proper positions of the bolt is evident.

Net Attachment shown below:

